

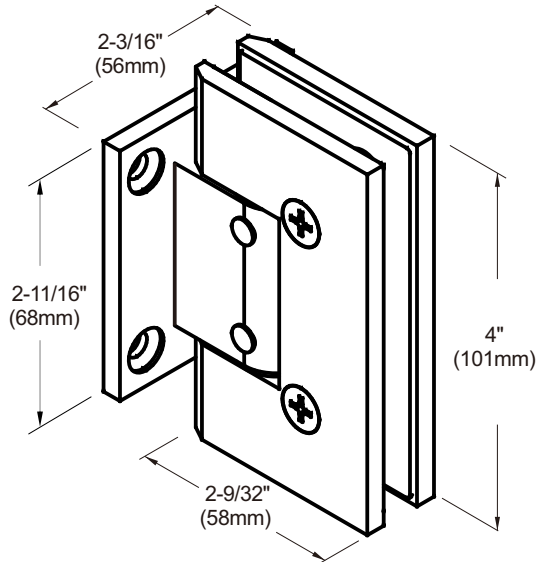

www.forgetools.net



## Viking

Code NO. **VIK485**

Wall Mount Hinge - Short Back Plate  
(Adjustable)

### Important Information:

This hinge contains a dual degree pivot pin. The pivot pin is set for normal door closing position. You have the option of altering the closing position of the door 5 degrees inward by utilizing the opposite side of the pivot pin, which has been pre-machined. Special order custom pivot pins are available that can be machined at any angle up to 45 degrees.

### Specifications:

**Glass Sizes:** 3/8" (10mm) to 1/2" (12mm) thick tempered safety glass

**Construction:** Solid brass

**Closing Type:** Self-centering when within 15° of closed position  
Cutout Required

**Includes:** Gaskets, screws and template

### Maximum Door Capacities for Two Hinges or Three Hinges:

**Maximum Door Weight:** 110 lbs.(50kg) 140 lbs.(63kg)

**Maximum Door Width:** 36"(914mm) 36"(914mm)

### Use of Gaskets:

**For 3/8" (10mm) Glass:** Use one thick gasket on each side

**For 1/2" (12mm) Glass:** Use one thick gasket on each side



www.forgetools.net

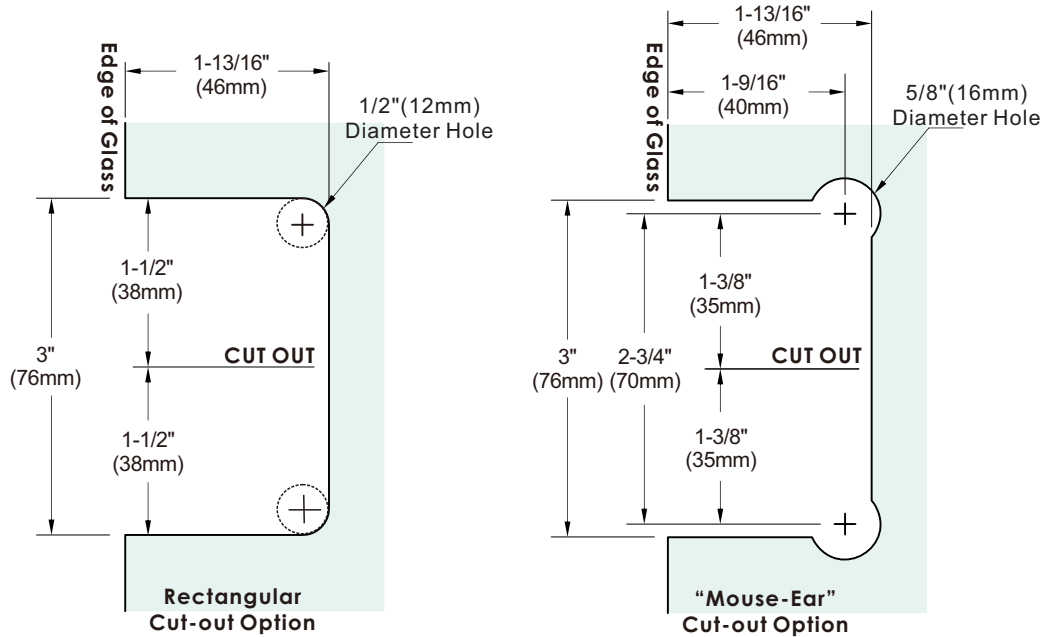

### Glass Cutout

**IMPORTANT: Project measurements from the edge of the glass.**

### Viking

Code NO. **VIK485**

Wall Mount Hinge - Short Back Plate  
(Adjustable)

Contact information: +1 (702) 279-3722

Email: [info@forgetools.net](mailto:info@forgetools.net)

[www.forgetools.net](http://www.forgetools.net)